

10.0 MOTORI ELETTRICI ELECTRIC MOTORS ELEKTROMOTOREN



Simbologia

Grand.	Denominazione	Unità di mis.
P_N	Potenzanominale	kW,HP
n	Velocità nominale	min ⁻¹
η	Rendimento	%
$\cos\varphi$	Fattore di potenza	—
I_{sp}	Corrente di spunto	A
I_N	Corrente nominale	A
M_{sp}	Coppia di spunto	Nm
M_{MAX}	Coppia massima	Nm
M_N	Coppia nominale	Nm
C	Capacità condens.	μF
U	Tensione	V
J	Momento d'inerzia	Kgm ²

(nel caso di motore autofrenante, al valore J riportato nelle tabelle, dovrà essere sommato quello del freno a c.c. o a c.a.)

Symbols

Size	Nomenclature	Unit of meas.
P_N	Nominal power	kW,HP
n	Nominal speed	min ⁻¹
η	Efficiency	%
$\cos\varphi$	Power factor	—
I_{sp}	Starting current	A
I_N	Nominal current	A
M_{sp}	Starting torque	Nm
M_{MAX}	Max torque	Nm
M_N	Nominal torque	Nm
C	Capacitor capacity	μF
U	Tension	V
J	Moment of inertia	Kgm ²

(In case of brake motors add to J value reported in the tables, the d.c. or a.c. brake value)

Kurzbezeichnungen

Größe	Bezeichnung	Maßeinheit
P_N	Nennleistung	kW,HP
n	Nennzahl	min ⁻¹
η	Wirkungsgrad	%
$\cos\varphi$	Leistungsfaktor	—
I_{sp}	Anlaufstrom	A
I_N	Nennstrom	A
M_{sp}	Anlaufmoment	Nm
M_{MAX}	Maximalmoment	Nm
M_N	Nennmoment	Nm
C	Kondensatorkapazität	μF
U	Spannung	V
J	Trägheitsmoment	Kgm ²

(beim Bremsmotor muß zum J-Wert der jeweilige Wert der Gs oder Ws-Bremse dazugezählt werden).



10.1 Caratteristiche generali

10.1 General characteristics

10.1 Allgemeine Merkmale

Tipi e versioni

Types and versions

Typen und Versionen

I motori a corrente alternata sono previsti nelle seguenti versioni:

A.c. motors are supplied in the following versions:

Die Wechselstrommotoren gibt es in folgenden Versionen:



TN

Trifase standard / Standard Threephase Motor / Standard - Drehstrommotor

DN

Trifase, polarità doppia / Threephase, double speed / Polumschaltbare Drehstrommotor

L'intera gamma attuale di motori, dalla grandezza 56 alla 132, utilizza carcasse e coperchi in alluminio pressofuso, ventole esterne bidirezionali costruite in materiale plastico e calotte copriventola in lamiera d'acciaio.

Tutte le caratteristiche dimensionali e costruttive dei motori STM sono conformi alle norme IEC, UNEL, CEI.

In the whole range, from size 56 to 132, housings and covers are made of die-cast aluminium, the external bidirectional fans are made of plastic material and the fan covers in steel sheets.

The dimensional and constructive characteristics of STM motors conform to IEC, UNEL, CEI specifications.

Alle Modelle der derzeitigen Motorenpalette, von Baugröße 56 bis 132, haben Gehäuse und Deckel aus Aluminium-Druckguß, die externen, bidirektionalen Ventilatoren Kunststoff und die Lüfterhauben aus Stahlblech. Maße und Konstruktionsmerkmale der STM-Motoren entsprechen den Anforderungen der IEC, UNEL und CEI-Normen.

10.2 Designazione

10.2 Designation

10.2 Bezeichnung

Tipo Type Typ	Grand. Size Größe	Potenza Power Leistung	N. poli N. poles Polzahl	Tensione Voltage Spannung	Frequenza Frequency Frequenz	Protezione Protection Schutzart	Isolamento Insulation Isolation	Forma costruttiva Mounting positions Bauform
TN	63	0.18	4	230/400	50	IP55	CL F	B5
TN	56	Kw	2	230-400V	50 Hz	IP55	CL F	B5
DN	(HP)	4	standard	standard	standard	standard	B14
MN	200		6	trifase				B3 pos.1
XN			8	threephase	60 Hz	IP44	CL H	standard
TF			2/4	Drehstrom	a richiesta	IP54	a richiesta	B3L pos.2
DF			4/6		on request	IP65	on request	B3L pos. 3
MF			4/8	standard	auf Anfrage	a richiesta	auf Anfrage	B3/B5
XF				monofase		on request	auf Anfrage	B3/B14
				singlephaseEi		auf Anfrage		a rich. /on req./auf
				nphasen				Anfrage

ALTRE SPECIFICHE OTHER SPECIFICATIONS WEITERE SPEZIFIKATIONEN	
tutti/all/alle	Albero bisporgente Double extended output shaft Beidseitig Abtriebswelle
XN XF	Condensatore di avviamento Starting Capacitor Anlaufkondensator
TF DF	Freno c.a. (standard per trifase) A.C. brake (standard on threephase) Ws-Bremse (Standard für Drehstrommotor)
TF MF DF	Freno c.c. (standard per monofase) D.C. brake (standard on single phase) Gs-Bremse (Standard für Einphasenmotor)
TF MF DF	Scheda frenatura rapida (per freno c.c.) Fast braking card (on D.C. brake) Schnellbrems-Karte (für Gs-Bremse)
TF MF DF	Leva di sblocco Hand release Manuelle Entsperrung
tutti/all/alle	Tropicalizzazione Tropicalization Tropenschutz
	Albero ridotto Reduced shaft Kleinwelle
	Flangia ridotta Special Flanges Sonderflansche

FLANGE RIDOTTE E MAGGIORATE DISPONIBILI SPECIAL FLANGES AVAILABLE LIEFERBARE SONDERFLANSCHEN

Tipo motore Motor type Motortyp	Tipo flangia / Flange type / Flanschttyp		
	B14 ridotta Reduced Reduziert	B14 maggiorata Oversize Übermaß	B5 ridotta Reduced Reduziert
63	56 B14	71 - 80 B14	—
71	63 B14	80 - 90 B14	63 B5
80	71 B14	90 - 100 B14	71 B5
90	80 B14	100 B14	71 B5
100	90 B14	132 B14	90 B5
112	90 B14	—	90 B5
132	—	—	112 B5



10.3 Caratteristiche meccaniche

10.3 Mechanical characteristics

10.3 Mechanische Merkmale

Forma costruttiva

Tutti i motori sono previsti nelle seguenti forme costruttive:

Fig. 10.1

Construction form

Standard all motors are supplied in the following types:

Bauform

Standard alle Motoren sind in folgenden Bauformen erhältlich:

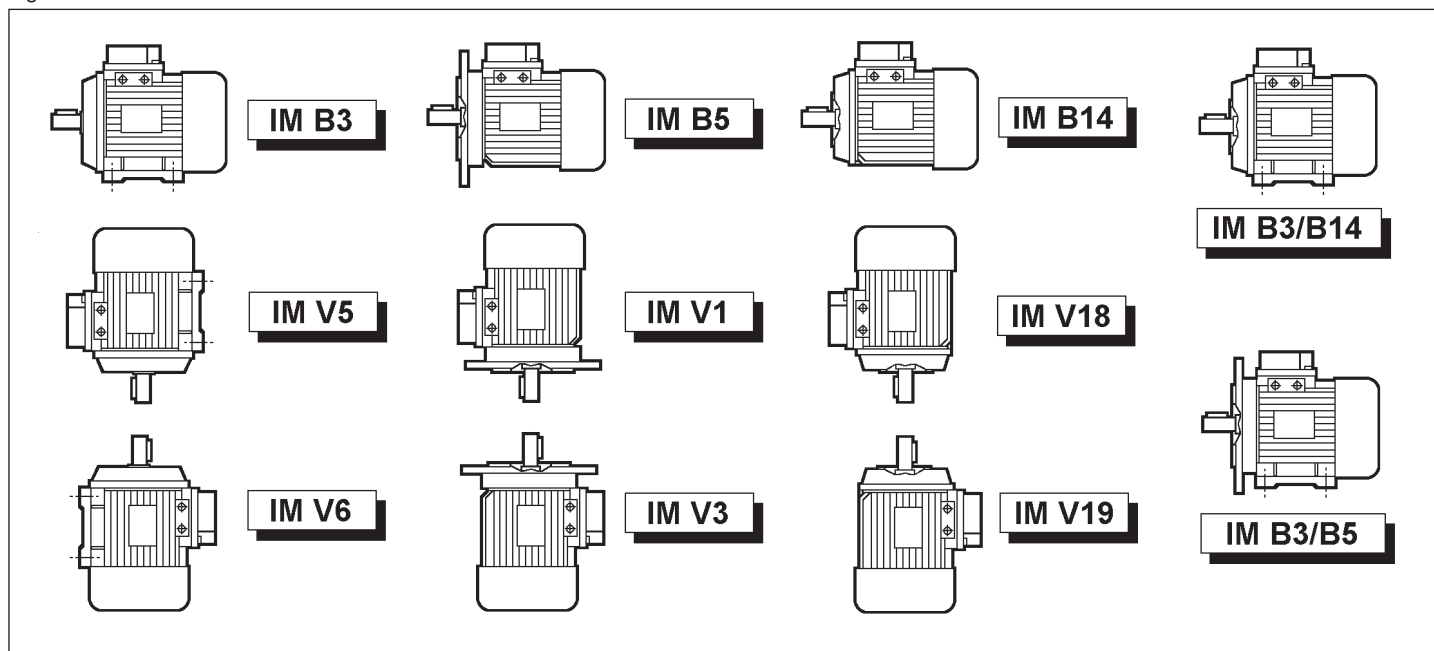

Protezioni

La protezione standard è la IP55; a richiesta i motori possono essere forniti con un grado di protezione IP54 e IP65.

Protection

Standard protection supplied is IP55. IP54 and IP65 protections are also available upon request.

Schutzarten

Die Standard Schutzart ist IP55. Auf Anfrage sind die Motoren jedoch auch IP54 und IP65 lieferbar.

Scatola morsettiera

Nelle forme costruttive con piede la scatola morsettiera può essere orientata in tre posizioni. Essa è posta normalmente in alto (1); a richiesta può essere collocata a destra (3) o, tramite esecuzione speciale, a sinistra (2).
Nei motori a polarità singola o doppia contiene 6 morsetti (a richiesta 12).

Terminal box

In the foot mounted types, the terminal box can be located in three different positions. On the standard type it is located on the top (1), upon request it can be located on the right (3) or on the left hand side (2).
Standard and double speed motors are equipped with a six terminals board (12 upon request).

Klemmenkasten

In der Bauform mit Fuß gibt es für den Klemmenkasten drei Montagemöglichkeiten. Normalerweise befindet er sich oben (1). Er kann aber auf Anfrage auch rechts (3) oder in Sonderausführung links (2) platziert werden. Bei ein-oder doppelpoligen Motoren enthält das Klemmbrett 6 Klemmen (auf Anfrage 12).

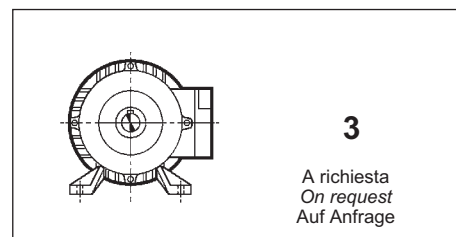
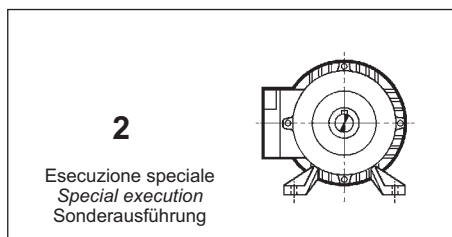
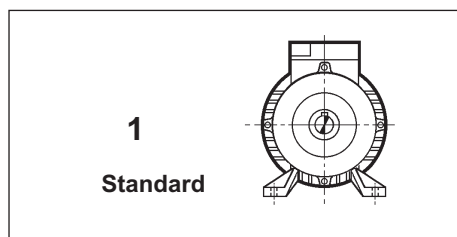

Carichi radiali

La tabella sottostante riporta i massimi carichi radiali (N) ammissibili sulla mezzeria della sporgenza dell'albero motore.

Radial loads

The table underneath lists the maximum radial loads (N) allowable on the centerline of the shaft extension.

Radialbelastungen

In der nachstehenden Tabelle sind die maximal zulässigen Radialbelastungen (N) auf die Mitte des Abtriebswelle angegeben.

min ⁻¹	Grandezza motore / Motor size / Motorbaugröße							
	56	63	71	80	90	100	112	132
3000	240	270	330	430	490	670	960	1370
1500	300	350	410	540	610	850	1210	1730
1000	350	400	470	610	700	970	1390	1980
750	—	400	470	610	770	1070	1390	1980



10.4 Caratteristiche elettriche motori trifase

Potenza

I valori di potenza riportati nelle tabelle di selezione sono calcolati per servizio continuo (S1) con temperatura ambiente max di 40 °C, altitudine inferiore a 1000 msl, alimentazione a tensione nominale, frequenza a 50Hz e valgono anche nel caso in cui la tensione nominale subisca delle variazioni contenute fra +5% e - 5%. Per condizioni operative e ambientali diverse, interpellare il ns. Servizio Clienti.

Tensione e frequenza

I valori di tabella sono relativi a tensione nominale 230 - 400 V e 50 Hz. E' ammessa tolleranza di tensione $\pm 5\%$. Se un motore normale viene impiegato a 60 Hz, indicativamente occorre considerare le seguenti variazioni:

P_N	C°	$\cos\varphi$	M_N	M_{MAX}/M_N	M_{sp}/M_N	n
=	=	=	- 17%	- 15%	- 30%	+ 20%

Classe di isolamento

Gli avvolgimenti, realizzati con filo a doppio smalto al massimo della tolleranza e sottoposti ad impregnazione sotto vuoto, sono isolati in **classe F** garantendo in tal modo un margine termico massimo di 155 °C, conforme alle prescrizioni delle principali normative. Per particolari applicazioni è possibile fornire (a richiesta) l'isolamento in classe H e motori sottoposti a trattamenti speciali per renderli atti a funzionare in ambienti umidi e corrosivi.

Schemi di collegamento motori trifase

Fig. 10.2

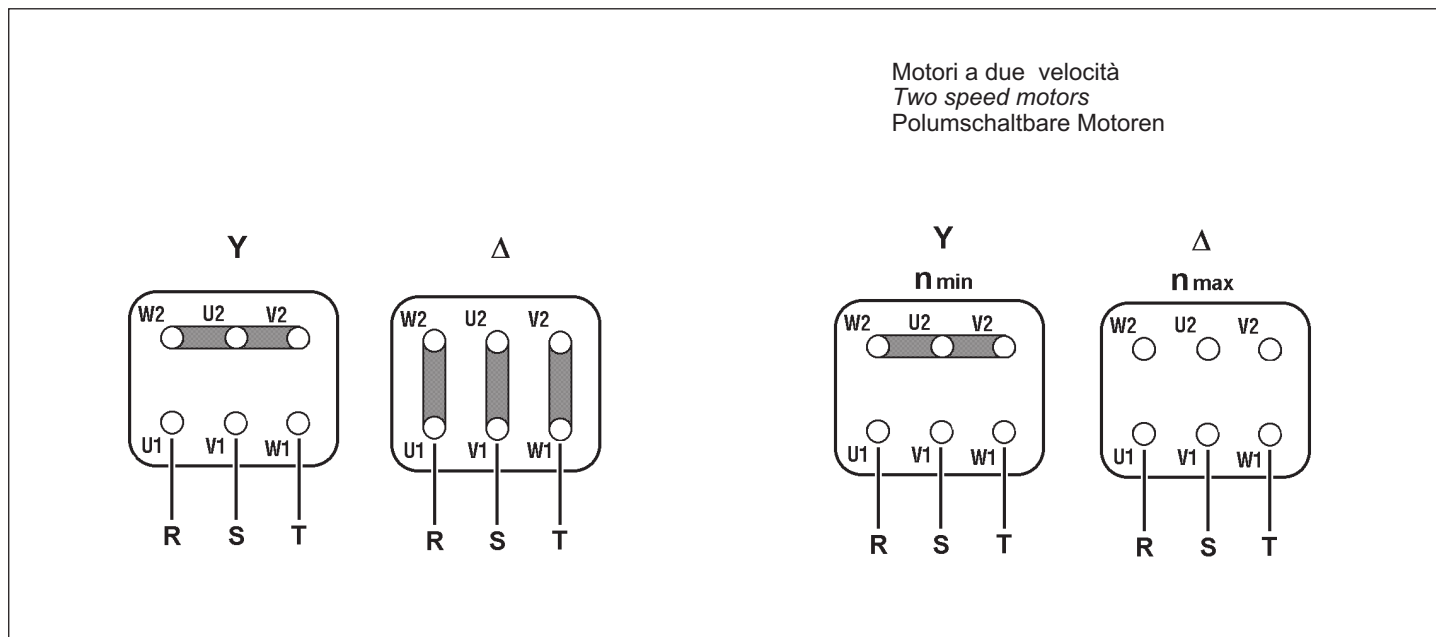

10.4 Electrical characteristics threephase motors

Power

Motor ratings listed in our selection tables are calculated for continuous duty (S1) in an ambient temperature of max 40°C, altitude below 1000 mt asl, normal voltage and 50Hz frequency. These values remain constant also in case of tension variations between + 5% and - 5%. For operating conditions different from the above, it is advisable to contact our Customer Service.

Frequency and tension

Values given in the table are relevant to nominal tension 230 - 400 V and 50 Hz. It is allowable a tension tolerance of $\pm 5\%$. Should a standard motor be used at 60Hz, the following variations have to be considered:

10.4 Elektrische Merkmale Drehstrommotoren

Leistung

Die in den Tabellen angegebenen Leistungen sind für Dauerbetrieb (S1), Umgebungstemperaturen von max. 40°C, Höhenlage unter 1000 m ü.M., Nennstromversorgung und Frequenz von 50 Hz berechnet. Sie gelten auch bei Nennspannung mit kleinen Schwankungen zwischen +5% und -5%. Bei anderen Arbeitsoder Umgebungsbedingungen wenden Sie sich bitte an unseren Kundendienst.

Spannung und Frequenz

Die Tabellenwerte beziehen sich auf eine Nennspannung von 230 - 400 V und 50 Hz. Spannungstoleranzen von $\pm 5\%$ sind zulässig. Wird ein normaler Motor bei 60 Hz betrieben, müssen folgende Abweichungen berücksichtigt werden:

Insulation class

Windings are made of copper wire with double thickness enamelling and are subjected to vacuum impregnation. They are also **class F** insulated granting a maximum thermal margin of 155 °C according to the main specifications. For particular applications it is possible to supply (upon request) class H insulated motors. Specially treated motors suitable to operate in humid and corrosive ambients are also available upon request.

Isolationsklasse

Die Wicklungen sind mit einer doppelten Lackschicht versehen und vakuumimprägniert. Sie sind nach **Klasse F** isoliert und garantieren somit einen den einschlägigen Normen entsprechenden maximalen Temperaturgrenzwert von 155°C. Für besondere Anforderungen können die Motoren auf Anfrage mit einer Isolierung nach Klasse H und speziellen Schutzbehandlungen für feuchte und korrosive Arbeitsumgebungen geliefert werden.

Threephase motor wiring diagram

Schaltungsplan für Drehstrommotoren



10.10 Servoventilazione

I motori elettrici STM possono essere dotati, a richiesta, di un sistema di ventilazione aggiuntivo alimentato in modo autonomo e inserito all'interno della calotta copriventola.

Nelle tabelle seguenti sono indicate le relative variazioni dimensionali riferite ai motori normali e autofrenanti.

10.10 Power cooling

Upon request, STM motors can be supplied with an additional ventilation system which is fed separately and installed inside the fan cover.

Following tables show the size changes relating to the standard and brake motors.

10.10 Servobelüftung

Die Elektromotoren STM können auf Anfrage mit einem zusätzlichen Lüftungssystem ausgestattet werden, welches autonom gespeist wird und im Inneren der Lüfterhaube untergebracht ist.

In den folgenden Tabellen sind die entsprechenden Abmessungsveränderungen bezüglich der Standard-Motoren und der Bremsmotoren angegeben.

Motore normale / Standard motor / Standard-Motor

TN-DN-MN	S1
56	22
63	33
71	22
80	26
90	21
100	29
112	22
132	33
160	0

Fig. 10.11

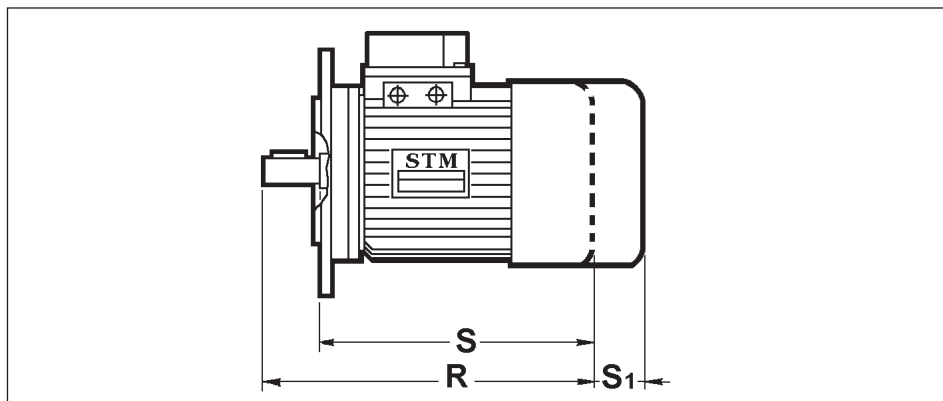

Motore autofrenante / Brake motor / Bremsmotor

TF-DF-MF	S1
56	0
63	38
71	25
80	25
90	30
100	30
112	0
132	0
160	0

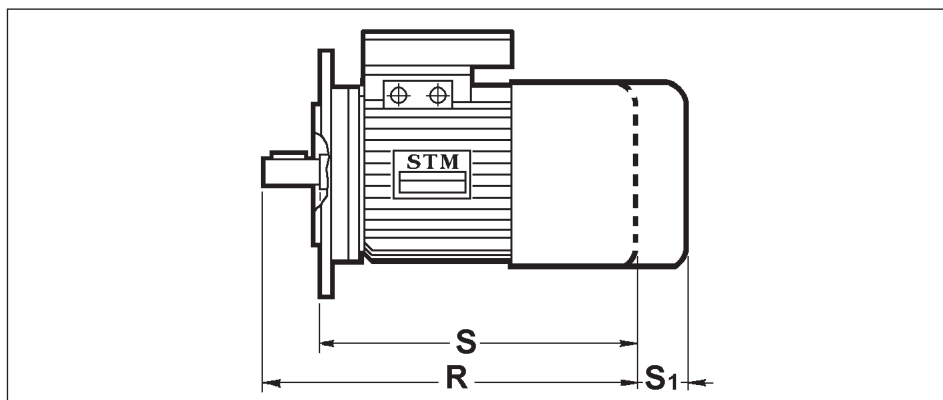

10.11 Dati tecnici
10.11 Technical data
10.11 Technische Daten

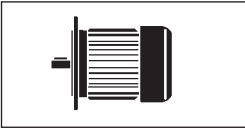
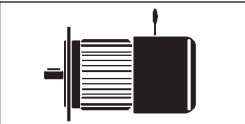
TN		Motori trifase standard Standard Threephase motors Standard-Drehstrommotoren
TF		Motori trifase autofrenanti Threephase brake motors Drehstrom- Bremsmotoren

2 poli/pole/polig 3000 min⁻¹

Tipo Type Typ	P _N kW	P _N HP	n _n rpm	η %	cosφ	I _N (400V) A	I _{sp} I _N	M _N Nm	M _{sp} M _N	M _{MAX} M _N	J Kgm ²	Kg (TN)	Kg (TF)
56 A	0.09	0.12	2730	59	0.71	0.45	2.8	0.32	2	2.2	0.00011	2.9	4.0
56 B	0.13	0.18	2730	60	0.73	0.50	3	0.45	2	2.3	0.00012	3	4.1
63 A	0.18	0.25	2740	64	0.76	0.60	3.5	0.63	2	2.2	0.00016	3.7	5.1
63 B	0.25	0.33	2750	65	0.78	0.85	3.5	0.85	2.1	2.3	0.00019	4.6	6.0
63 C	0.37	0.50	2770	68	0.80	1	3.8	1.30	2	2.4	0.00029	4.7	6.1
71 A	0.37	0.50	2800	70	0.81	1.1	4.3	1.29	2.2	2.5	0.00036	5.5	6.9
71 B	0.55	0.75	2820	73	0.81	1.4	4.5	1.85	2.2	2.5	0.00047	6.5	7.9
71 C	0.75	1	2820	78	0.82	1.7	4.5	2.58	2.2	2.6	0.00057	7.2	8.6
80 A	0.75	1	2830	77	0.83	1.8	4.8	2.58	2.3	2.7	0.00085	8.7	10.6
80 B	1.1	1.5	2830	79	0.84	2.5	5	3.78	2.3	2.7	0.00105	10.8	12.7
90 S	1.5	2	2840	79	0.83	3.6	5.5	5.1	2.5	2.8	0.00145	12.9	16.0
90 L	2.2	3	2850	81	0.87	4.8	5.6	7.5	2.5	3	0.00191	14.8	17.9
100 A	3	4	2870	83	0.88	6.4	5.8	10	2.4	3	0.00299	22	27.6
100 B	4	5.5	2880	84	0.88	8.5	6.2	13.4	2.5	3.2	0.00407	27	32.6
112 A2	4	5.5	2880	84	0.88	9.3	6.8	13.4	2.5	3.2	0.00520	29	38.7
132 SA	5.5	7.5	2860	85	0.88	11.5	6.5	18.3	2.4	3	0.01080	44	61
132 SB	7.5	10	2870	85	0.88	16.5	6.8	25	2.4	3.2	0.01300	50	76
132 MC	9.2	12.5	2880	85	0.88	19	6.8	30.6	2.4	3.2	0.01639	59	82
132 MD	11	15	2880	85	0.88	20	6.7	36.5	2.4	3.2	0.01873	65	82
160 MA	11	15	2920	88	0.87	21	7	36	2	2.2	0.03300	115	—
160 MB	15	20	2920	89	0.87	28	7	49	2	2.2	0.045	125	—
160 L	18.5	25	2920	89	0.87	34	7	61	2	2.2	0.056	145	—
180 M	22	30	2940	89	0.89	40	7	72	2	2.2	0.073	173	—
200 LA	30	40	2940	90	0.89	54	7	98	2	2.2	0.120	232	—
200 LB	37	50	2950	91	0.89	66	7	120	2	2.2	0.150	250	—
225 M2K	45	60	2940	93	0.91	76.6	7.2	146	2.5	3.2	0.150	275	—
250 M2K	55	75	2945	93.5	0.91	93.1	7.5	178	2.3	3.3	0.210	340	—
280 S2K	75	100	2955	93	0.91	127	7.5	242	2	2.9	0.470	485	—
280 M2K	90	125	2955	93	0.91	153	6.9	291	1.7	2.9	0.520	515	—
315 S2	110	150	2960	94	0.92	183	7.2	355	2.1	3.4	0.850	720	—
315 M2K	132	175	2960	94.5	0.92	219	7.5	426	2.3	3.4	1.020	770	—
315 LA2	160	215	2970	94.5	0.92	265	7.2	514	1.8	2.8	1.420	970	—
315 LB2	200	270	2975	95	0.94	322	7.2	642	1.8	2.8	1.780	1110	—



10.11 Dati tecnici

10.11 Technical data

10.11 Technische Daten

TN

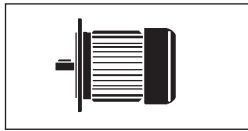

Motori trifase standard
Standard Threephase motors
Standard-Drehstrommotoren

TF

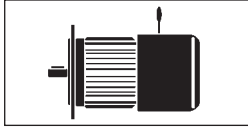

Motori trifase autofrenanti
Threephase brake motors
Drehstrom- Bremsmotoren

4 poli/pole/polig 1500 min⁻¹

Tipo Type Typ	P _N kW	P _N HP	n _n rpm	η %	cosφ	I _N (400V) A	I _{sp} I _N	M _N Nm	M _{sp} M _N	M _{MAX} M _N	J Kgm ²	Kg (TN)	Kg (TF)
56B	0.09	0.12	1340	56	0.65	0.40	2.3	0.65	1.8	2	0.00018	2.9	4.0
63 A	0.13	0.18	1360	60	0.68	0.60	2.4	0.93	2	2.2	0.00025	3.7	5.1
63 B	0.18	0.25	1380	62	0.69	0.70	2.6	1.29	2.2	2.3	0.00029	4.5	5.9
71 A	0.25	0.33	1400	63	0.71	0.90	3	1.7	2.2	2.3	0.00074	5.4	6.8
71 B	0.37	0.50	1400	68	0.71	1.2	3.2	2.52	2.3	2.6	0.00096	6.4	7.8
71 C	0.55	0.75	1400	72	0.75	1.5	3.9	3.75	2.4	2.5	0.00117	7	8.4
80 A	0.55	0.75	1410	74	0.78	1.6	3.9	3.80	2.4	2.6	0.00191	8.5	10.4
80 B	0.75	1	1410	74	0.78	2.1	4	5	2.2	2.4	0.00254	10.5	12.4
80C	0.95	1.3	1410	74	0.78	2.8	4	6.56	2.3	2.6	0.00285	11.5	13.4
90 S	1.1	1.5	1410	74	0.78	3	4.3	7.5	2.2	2.4	0.00242	12.5	15.6
90 L	1.5	2	1420	78	0.80	3.8	4.6	10	2.3	2.6	0.00321	14	17.1
90 LB	1.8	2.5	1420	78	0.80	4.6	4.7	12.1	2.3	2.6	0.00400	16	19.1
100 A	2.2	3	1430	80	0.82	5.4	4.8	15	2.2	2.5	0.00520	20	25.6
100 B	3	4	1430	81	0.82	7	5	20	2.3	2.6	0.00668	24	29.6
112 A	4	5.5	1430	83	0.83	9	5.2	27	2.4	2.7	0.01052	29	38.7
132 SA	5.5	7.5	1430	83	0.83	12	6	37	2.5	2.8	0.01940	42	61
132 MB	7.5	10	1430	83	0.83	16	6.1	50	2.5	2.8	0.02688	53	76
132 MC	9.2	12.5	1430	85	0.85	18	6.1	61.8	2.5	2.8	0.03059	58	82
132 MD	11	15	1430	85	0.85	22	6	75	2	2.5	0.03632	49	81
160 M	11	15	1450	89	0.86	21	7	73	2.0	2.3	0.06200	122	—
160 L	15	20	1450	89	0.86	29	7	99	2.2	2.3	0.08300	142	—
180 M	18.5	25	1470	91	0.86	34	7	120	2.0	2.2	0.12700	174	—
180 L	22	30	1470	92	0.86	41	7	143	2.0	2.2	0.15300	192	—
200 L	30	40	1470	92	0.87	54	7	195	2.0	2.2	0.24900	253	—
225 S4K	37	50	1465	92.2	0.85	67.9	6.7	241	2.6	2.6	0.27	260	—
225 M4K	45	60	1465	92.5	0.85	82.3	6.9	293	2.5	2.5	0.32	280	—
250 M4K	55	75	1470	93.3	0.85	99.8	6.8	357	2.4	2.4	0.50	350	—
280 S4K	75	100	1480	94	0.86	134	7.2	484	2.1	2.3	1.00	495	—
280 M4K	90	125	1485	94.3	0.88	156	7.2	578	2.3	2.3	1.20	545	—
315 S4	110	150	1485	95.4	0.88	189	6.8	707	2.3	2.8	2.19	790	—
315 M4	132	175	1485	95.9	0.89	222	7	848	2.4	2.8	2.70	885	—
315 LA4	160	215	1485	96	0.88	273	6.8	1028	1.9	2.2	3.57	1110	—
315 LB4	200	270	1485	96	0.90	333	6.8	1285	1.9	2.0	3.97	1150	—

10.11 Dati tecnici
10.11 Technical data
10.11 Technische Daten

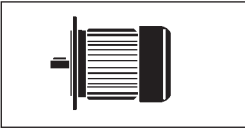
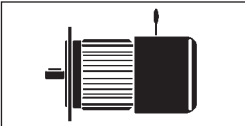
TN		Motori trifase standard Standard Threephase motors Standard-Drehstrommotoren
TF		Motori trifase autofrenanti Threephase brake motors Drehstrom- Bremsmotoren

6 poli /pole/polig 1000 min⁻¹

Tipo Type Typ	P _N kW	P _N HP	n _n rpm	η %	cosφ	I _N (400V) A	I _{sp} I _N	M _N Nm	M _{sp} M _N	M _{MAX} M _N	J Kgm ²	Kg (TN)	Kg (TF)
63 A	0.09	0.12	850	52	0.60	0.5	2.2	1	1.8	2	0.00029	3.8	5.2
63 B	0.13	0.16	870	54	0.60	0.6	2.3	1.3	1.8	2	0.00034	4.6	6.0
71 A	0.18	0.25	880	56	0.62	0.8	2.5	1.95	1.8	2	0.00074	5.5	6.9
71 B	0.25	0.33	900	60	0.65	1	2.9	2.65	1.9	2.2	0.00096	6.5	7.9
80 A	0.37	0.50	910	62	0.66	1.27	3.2	3.88	1.9	2.2	0.00191	8.5	10.4
80 B	0.55	0.75	910	66	0.70	1.8	3.5	5.77	2	2.3	0.00254	10.5	12.4
90 S	0.75	1	920	68	0.70	2.4	3.5	7.79	1.8	2	0.00242	12.5	15.6
90 L	1.1	1.5	920	70	0.70	3.4	3.5	11.4	1.8	2	0.00398	14	17.1
100 A	1.5	2	940	75	0.72	4.2	4	15.2	1.8	2	0.00519	24	29.6
112 A	2.2	3	940	80	0.77	5.7	5	22.4	1.9	2.4	0.00620	34	43.7
132 SA	3	4	940	82	0.78	7.6	5.4	30.5	2	2.5	0.01940	44	61
132 MB	4	5.5	940	82	0.80	9	5.3	40.5	2	2.5	0.02688	55	72
132 MC	5.5	7.5	940	82	0.80	12.7	5.3	57	2	2.5	0.03430	60	77
160 M	7.5	10	960	87	0.77	16.5	6.5	75	2.0	2.3	0.093	110	—
160 L	11	15	960	88	0.79	23	6.5	110	2.0	2.3	0.127	130	—
180 L	15	20	970	90	0.81	30	6.5	148	1.8	2.0	0.198	1892	—
200 LA	18.5	25	970	90	0.83	36	6.5	182	1.8	2.0	0.292	220	—
200 LB	22	30	970	90	0.83	43	6.5	217	1.8	2.0	0.324	246	—
225 M6K	30	40	975	90	0.84	57.1	6	294	2.1	2.4	0.460	270	—
250 M6K	37	50	980	91	0.84	69.6	6.3	360	2.3	2.5	0.650	335	—
280 S6K	45	60	980	92.5	0.83	84.6	6.5	438	2.2	2.3	1.200	440	—
280 M6K	55	75	980	92.5	0.85	101	6.1	536	2.2	2.3	1.300	460	—
315 S6	75	100	985	94.7	0.85	134	6.3	727	2.2	2.4	3.040	745	—
315 M6	90	125	985	94.7	0.84	162	6.3	872	2	2.2	3.360	780	—
315 LA6	110	150	985	95	0.90	185	6.7	1066	1.6	2.4	4.540	960	—
315 LB6	132	175	985	95.2	0.91	219	7	1279	1.7	2.4	5.130	1010	—

8 poli /pole/polig 750 min⁻¹

Tipo Type Typ	kW	HP	n _n rpm	η %	cosφ	I _N (230V) A	I _{sp} I _N	M _N Nm	M _{sp} M _N	M _{MAX} M _N	C μF	J Kgm ²	Kg (MN)	Kg (MF)
63 B	0.07	0.10	660	42	0.56	0.6	2	1	1.8	2	0.00029	4.5	5.9	
71 B	0.12	0.16	670	46	0.60	0.8	2	1.72	1.8	2	0.00096	6.5	7.9	
80 A	0.18	0.25	690	50	0.60	0.9	2.5	2.5	1.8	2	0.00191	8.4	10.3	
80 B	0.25	0.33	700	50	0.60	1	2.5	3.4	1.8	2	0.00254	10.4	12.3	
90 S	0.37	0.5	700	58	0.60	1.6	3	5	2	2.2	0.00242	12.3	15.4	
90 L	0.55	0.75	700	62	0.62	2.2	3.2	7.5	2	2.2	0.00320	13.8	16.9	
100 A	0.75	1	700	70	0.64	2.6	3.5	10.4	2	2.4	0.00519	23	28.6	
100 B	1.1	1.5	700	72	0.64	3.6	3.5	15.2	2	2.4	0.00668	30	35.6	
112 A	1.5	2	700	74	0.66	4.7	4	20.7	2.1	2.4	0.01220	33	42.7	
132 SA	2.2	3	700	75	0.65	7	4.1	30	2.2	2.4	0.01940	44	—	
132 MB	3	4	700	77	0.65	9	4.3	41	2.2	2.4	0.03430	55	—	



10.11 Dati tecnici

10.11 Technical data

10.11 Technische Daten

DN

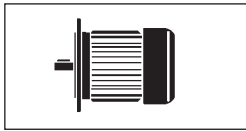

Motori trifase a doppia polarità
Threephase two speed motors
Polumschaltbare - Drehstrommotoren

DF

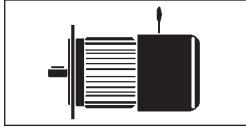

Motori trifase autofrenanti a doppia polarità
Threephase two speed brake motors
Polumschaltbare - Bremsmotoren

2/4 poli/pole/polig 3000/1500 min⁻¹

Tipo Type Typ	P _N kW	P _N HP	n _n rpm	I _N (400V) A	I _{sp} I _N	M _N Nm	M _{sp} M _N	M _{MAX} M _N	J Kgm ²	Kg (DN)	Kg (DF)
63 A	0.18/0.12	0.25/0.16	2750/1350	0.75/0.5	3/2.5	0.65/0.85	1.3/1.3	1.4/1.5	0.00025	3.7	5.1
63 B	0.22/0.15	0.30/0.20	2760/1360	0.83/0.6	3/2.5	0.76/1	1.3/1.3	1.4/1.5	0.00029	4.5	5.9
71 A	0.30/0.20	0.40/0.28	2780/1400	1.2/1	3/3	1/1.4	1.5/1.3	1.6/1.8	0.00074	5.4	6.8
71 B	0.44/0.30	0.60/0.40	2780/1400	1.6/1.3	3/3	1.5/2	1.5/1.4	1.6/1.8	0.00096	6.4	7.8
80 A	0.60/0.45	0.8/0.6	2780/1400	2/1.6	3.5/3.5	2/3	1.5/1.3	1.8/1.8	0.00191	8.4	10.3
80 B	0.8/0.6	1.1/0.8	2800/1400	2.5/1.9	3.5/3.5	2.7/4	1.6/1.3	1.8/1.8	0.00254	10.5	12.4
90 S	1.4/1	1.9/1.35	2830/1420	3.5/2.8	4/3.5	4.7/6.7	1.8/1.5	2/1.8	0.00242	12.5	15.6
90 L	1.8/1.2	2.5/1.7	2830/1420	4.5/3.1	5/4.5	6/8	2.1/2	2.2/2	0.00321	14	17.1
90 LL	2.2/1.5	3/2	2830/1420	5.5/3.7	5/4.5	7.5/10	2.1/2	2.4/2.2	0.00398	16	19.1
100 A	2.5/1.8	3.4/2.5	2830/1420	6.2/4.5	5/4.5	8.3/12	2.3/1.9	2.6/2	0.00519	20	25.6
100 B	3.3/2.5	4.5/3.5	2850/1430	8.1/6.9	6/5	11/16.7	2.4/2.2	2.8/2.4	0.00668	24	29.6
112 A	4.5/3.3	6/4.5	2850/1430	9.8/7	6/5	15/22	2.4/2.3	3/2.4	0.01223	34	43.7
132 M	5.5/4	7.5/5.5	2910/1450	13/9.5	6.5/5.5	18.5/26.5	2.4/2.3	3/2.5	0.01080	44	60
132 S	7.5/6.2	10/8.5	2910/1450	16.5/13.5	7/6	25/42	2.5/2.8	3/2.5	0.01639	59	75

4/6 poli/pole/polig 1500/1000 min⁻¹

Tipo Type Typ	P _N kW	P _N HP	n _n rpm	I _N (400V) A	I _{sp} I _N	M _N Nm	M _{sp} M _N	M _{MAX} M _N	J Kgm ²	Kg (DN)	Kg (DF)
71 B	0.30/0.22	0.40/0.30	1380/890	1/0.9	3.5/2	2/2.3	1.3/1.3	2/1.8	0.00057	6.5	7.9
80 A	0.37/0.26	0.50/0.35	1410/900	1.4/1.2	3.5/2.5	2.5/2.7	1.3/1.4	1.9/2.1	0.00191	8.5	10.4
80 B	0.55/0.45	0.75/0.60	1420/920	2/1.8	3.5/2.5	3.7/4.6	1.5/1.8	2.1/2.3	0.00254	10.5	12.4
90 S	0.75/0.5	1/0.7	1420/920	2.4/2.1	4/2.5	5/5.2	1.4/1.3	2.1/2	0.00242	12.5	15.6
90 L	1.1/0.75	1.5/1	1470/900	3.9/3.7	4.2/2.5	7.3/7.9	1.4/1.4	2.1/2.1	0.00321	14	17.1
100 A	1.3/0.9	1.8/1.2	1430/920	4/3.8	4.5/3	8.6/9.3	1.4/1.4	2.1/2.2	0.00519	21	26.6
100 B	1.5/1.1	2/1.5	1430/930	5.4/4.8	4.5/3	10/11.2	1.4/1.5	2.2/2.3	0.00668	24	29.6
112 A	2.2/1.5	3/2	1430/930	6/5.8	4.5/3.5	14.7/15.4	1.4/1.3	1.7/1.6	0.01052	34	43.7
132 S	2.5/1.8	3.5/2.5	1420/930	6.5/6	5.5/4.8	17/18.8	1.6/1.5	1.8/1.6	0.01080	44	60
132 M	4/3	5.5/4	1440/930	8.5/6.9	6.5/5.5	27/31.4	1.8/1.7	2/1.9	0.01639	59	75

4/8 poli/pole/polig 1500/750 min⁻¹

Tipo Type Typ	P _N kW	P _N HP	n _n rpm	I _N (400V) A	I _{sp} I _N	M _N Nm	M _{sp} M _N	M _{MAX} M _N	J Kgm ²	Kg (DN)	Kg (DF)
63 B	0.09/0.04	0.12/0.06	1360/660	0.6/0.55	3.5/2	0.6/0.57	1.3/1.3	1.9/1.8	0.00029	4.6	6.0
71 B	0.15/0.09	0.20/0.12	1390/690	0.7/0.65	3.5/2	1/1.2	1.3/1.3	1.9/1.8	0.00096	6.5	7.9
80 A	0.29/0.18	0.40/0.25	1410/700	1.3/1.1	3.5/2.5	1.9/2.4	1.5/1.8	2/1.8	0.00191	8.5	10.4
80 B	0.37/0.22	0.5/0.30	1420/700	1.8/1.7	3.5/2.5	2.4/3	1.5/1.8	2/1.8	0.00254	10.5	12.4
90 S	0.6/0.26	0.8/0.35	1430/700	1.9/1.8	4/2.5	4/3.5	1.4/1.3	2/1.8	0.00242	12.5	15.6
90 L	1/0.5	1.3/0.7	1430/700	2.6/2.5	4.5/2.5	6.8/6.8	1.4/1.4	2/1.8	0.00321	14	17.1
100 B	1.5/0.75	2/1	1430/700	3.8/3.6	4.5/3	10/10	1.4/1.5	2/1.8	0.00668	24	29.6
112 A	2.2/1.3	3/1.8	1410/700	4.7/4.3	4.5/3.4	15.2/17.7	1.6/1.5	1.9/1.9	0.01223	34	44
132S	3.1/1.7	4.2/2.3	1420/710	7/5.9	4.7/3.8	21.2/23.3	1.8/1.8	2/2.1	0.01080	44	60
132 M	5/2.8	6.8/3.8	1440/720	13/8.2	5.2/4.3	33.7/3.7	1.8/1.8	2.2/2.3	0.01639	59	75



10.12 Dimensioni

10.12 Dimensions

10.12 Abmessungen

Motori standard

Standard motors

Standard Motoren

TN

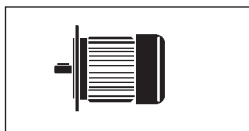

DN

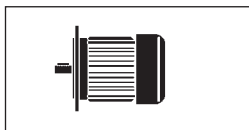

MN

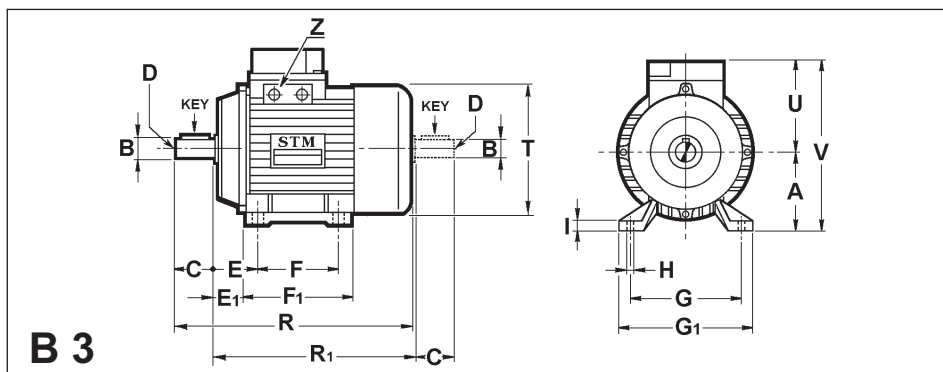
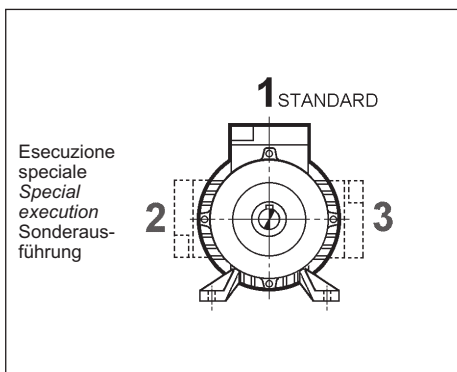
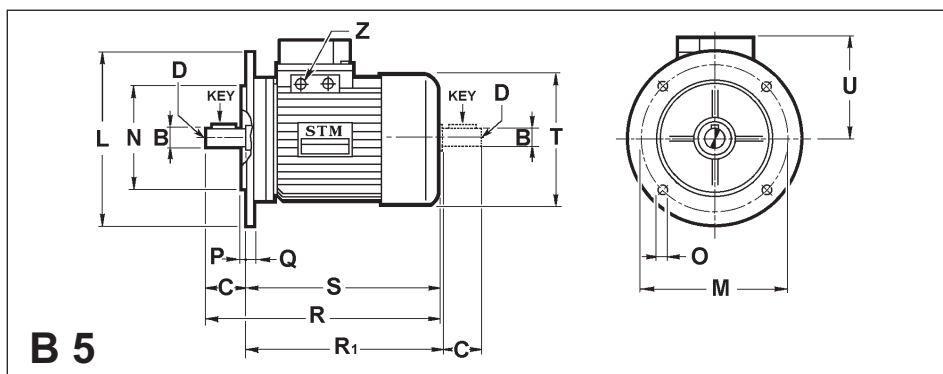
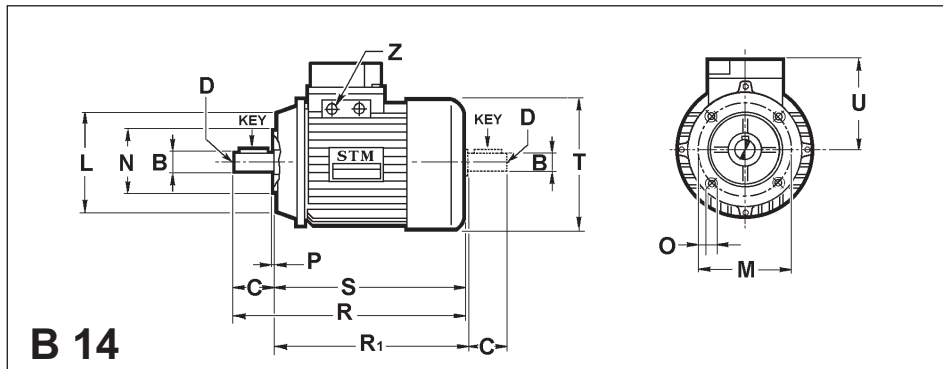
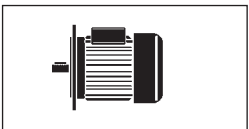



10.12 Dimensioni
10.12 Dimensions
10.12 Abmessungen

	B3										B14					
	A	E	E1	F	F1	G	G1	H	I	V	L	M	N	O	P	S
56	56	36	26	71	90	90	108	6	9	149	80	65	50	M5	2.5	167
63	63	40	28	80	105	100	120	7	10	161	90	75	60	M5	2.5	192
71	71	45	36	90	108	112	136	7	11	178	105	85	70	M6	2.5	220
80	80	50	38	100	125	125	154	9.5	11	204	120	100	80	M6	3	235
90S	90	56	41	100	130	140	174	9.5	13	217	140	115	95	M8	3	250
90L	90	56	41	125	155	140	174	9.5	13	217	140	115	95	M8	3	275
100	100	63	46	140	175	160	192	12	14	238	160	130	110	M8	3.5	310
112	112	70	53	140	180	190	234	12	14	262	160	130	110	M8	3.5	330
132S	132	89	60	140	180	216	256	12	16	310	200	165	130	M10	4	370
132M	132	89	60	178	218	216	256	12	16	310	200	165	130	M10	4	410
160 M	160	108	83	210	260	254	310	15	22	400						
160 L	160	108	72	254	320	254	330	15	22	400						
180 M	180	121	80	241	315	279	355	19	24	450						
180 L	180	121	80	279	353	279	355	19	24	450						
200 L	200	133	91	305	400	318	395	19	27	500						
225 S	225	149	61	286	450	356	435	19	30	550						
225 M	225	149	101	311	450	356	435	19	30	550						
250 M	250	168	108	349	460	406	490	24	33	610						
280 S	280	190	106	368	525	457	550	24	38	670						
280 M	280	190	106	419	576	457	550	24	38	670						
315 S	315	216	112	406	615	508	640	28	48	865						
315 M	315	216	112	457	665	508	640	28	48	865						
315 L	315	216	97	508	745	508	640	28	48	865						

	B3 - B5 - B14													B5							
	B		C		D	R		R1		T	U	Z	Key		L	M	N	O	P	Q	S
	2 p	4/6/8 p	2 p	4/6/8 p		2 p	4/6/8 p	2 p	4/6/8 p				2 p	4/6/8 p							
56	9 j6	9 j6	20	20	M4	187	187	171	171	110	93	PG11	3x3x15	3x3x15	120	100	80	7	3	8	167
63	11 j6	11 j6	23	23	M4	215	215	193	193	123	98	PG11	4x4x15	4x4x15	140	115	95	9	3	9	192
71	14 j6	14 j6	30	30	M5	250	250	218	218	138	107	PG13.5	5x5x20	5x5x20	160	130	110	9	3.5	9	220
80	19 j6	19 j6	40	40	M6	275	275	237	237	156	124	PG16	6x6x30	6x6x30	200	165	130	11	3.5	10	235
90S	24 j6	24 j6	50	50	M8	300	300	256	256	176	127	PG16	8x7x40	8x7x40	200	165	130	11	3.5	10	250
90L	24 j6	24 j6	50	50	M8	325	325	281	281	176	127	PG16	8x7x40	8x7x40	200	165	130	11	3.5	10	275
100	28 j6	28 j6	60	60	M10	370	370	309	309	192	138	PG16	8x7x40	8x7x40	250	215	180	14	4	14	310
112	28 j6	28 j6	60	60	M10	390	390	331	331	216	150	PG16	8x7x40	8x7x40	250	215	180	14	4	14	330
132S	38 k6	38 k6	80	80	M12	450	450	376	376	257	178	PG21	10x8x70	10x8x70	300	265	230	14	4	20	370
132M	38 k6	38 k6	80	80	M12	490	490	411	411	257	178	PG21	10x8x70	10x8x70	300	265	230	14	4	20	408
160 M	42 k6	42 k6	110	110	M16	600	600	495	495	310	340	PG21	12x8	12x8	350	300	250	19	5	16	490
160 L	42 k6	42 k6	110	110	M16	640	640	540	540	310	340	PG21	12x8	12x8	350	300	250	19	5	16	535
180 M	48 k6	48 k6	110	110	M16	670	670	570	570	360	270	PG29	14x8	14x9	350	300	250	19	5	18	560
180 L	48 k6	48 k6	110	110	M16	710	710	610	610	360	270	PG29	14x8	14x9	350	300	250	19	5	18	600
200 L	55 k6	55 k6	110	110	M20	775	775	675	675	400	300	PG36	16x10	16x10	400	350	300	19	5	18	665
225 S	—	60 k6	—	140	M20	—	820	690	690	450	325	PG36	—	18x11	450	400	350	19 •	5	20	680
225 M	55 k6	60 k6	110	140	M20	815	845	715	715	450	325	PG36	16x10	18x11	450	400	350	19 •	5	20	705
250 M	60 k6	65 k6	140	140	M20	930	930	800	800	495	360	PG36	18x11	18x11	550	500	450	19 •	5	22	790
280 S	65 k6	75 k6	140	140	M20	1000	1000	880	880	555	390	PG42	18x11	20x12	550	500	450	19 •	5	22	860
280 M	65 k6	75 k6	140	140	M20	1050	1050	930	930	555	390	PG42	18x11	20x12	550	500	450	19 •	5	22	910
315 S	65 k6	80 k6	140	170	M20	1155	1185	1040	1040	630	550	PG48	18x11	22x14	660	600	550	24 •	6	25	1015
315 M	65 k6	80 k6	140	170	M20	1210	1240	1095	1095	630	550	PG48	18x11	22x14	660	600	550	24 •	6	25	1070
315 L	65 k6	80 k6	140	170	M20	1210	1240	1095	1095	630	550	PG48	18x11	22x14	660	600	550	24 •	6	25	1070

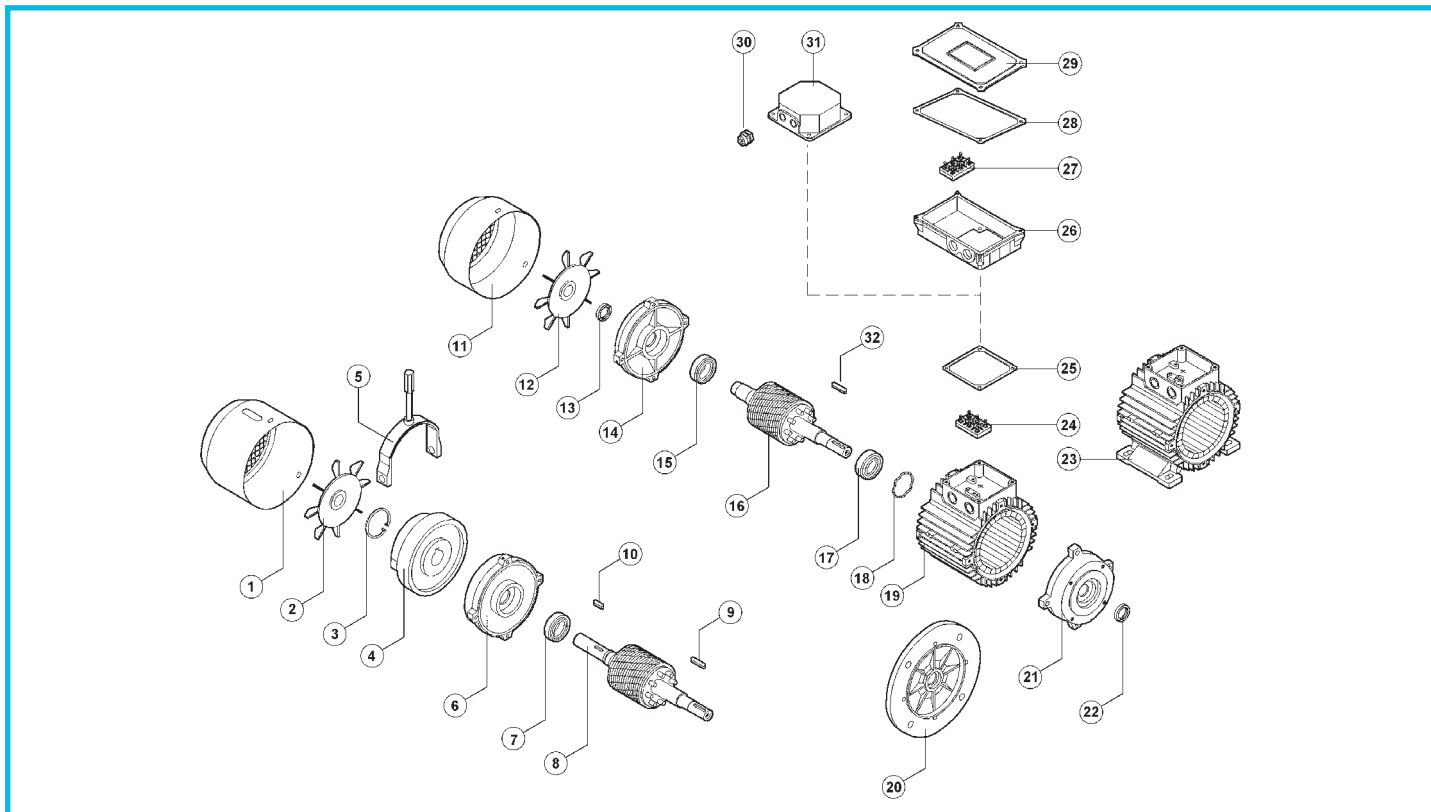
Fig. 10.12



1	Copriventola	Fan cover	Lüfterhaube
2	Ventola	Fan	Lüfter
3	Seeger	Circlip	Seeger
4	Freno	Brake	Bremse
5	Leva di sblocco	Hand release	Handlüftung
6	Scudo posteriore	Non drive end shield	Hinteres Lagerschild
7	Cuscinetto	Bearing	Lager
8	Rotore	Rotor	Rotor
9	Linguetta	Key	Keil
10	Linguetta	Key	Keil
11	Copriventola	Fan cover	Lüfterhaube
12	Ventola	Fan	Lüfter
13	Anello di tenuta	Oilseal	Dichtring
14	Scudo posteriore	Non drive end shield	Hinteres Lagerschild
15	Cuscinetto	Bearing	Lager
16	Rotore	Rotor	Rotor
17	Cuscinetto	Bearing	Lager
18	Molla di precarico	Pre load spring	Vorspannfedern
19	Cassa B5-B14	B5/B14 housing	Gehäuse B5-B14
20	Flangia B5	B5 Flange	Flansch B5
21	Scudo anteriore (B14)	Drive end shield (B14)	Vorderes Lagerschild (B14)
22	Anello di tenuta	Oilseal	Dichtring
23	Cassa con piedi	Foot casing	Gehäuse mit Fuß
24	Morsettiera	Terminal board	Klemmbrett
25	Guarnizione	Gasket	Dichtung
26	Scatola morsettiera	Terminal box	Klemmenkasten
27	Morsettiera	Terminal board	Klemmbrett
28	Guarnizione	Gasket	Dichtung
29	Coperchio morsettiera	Terminal box cover	Klemmenkastendeckel
30	Pressacavo	Cable gland	Kabelverschraubung
31	Scatola morsettiera	Terminal box	Klemmenkasten
32	Linguetta	Key	Keil



Potenza richiesta / Required power / Benötigte Leistung

$$P = \frac{m \cdot g \cdot v}{6 \cdot 10^4}$$

Sollevamento / *Lifting* / Heben

$$P = \frac{M \cdot n}{9550}$$

Rotazione / *Rotation* / Drehung

$$P = \frac{F \cdot v}{6 \cdot 10^4}$$

Traslazione / *Linear movement* / Linearbewegung

$$M = \frac{9550 \cdot P}{n}$$

Coppia / *Torque* / Drehmoment

$$F = 1000 \cdot \frac{M}{r}$$

Forza / *Force* / Kraft

$$v = \frac{2r \cdot \pi \cdot n}{1000}$$

Velocità lineare / *Linear speed* / Lineargeschwindigkeit

Momento d'inerzia

Moment of inertia

Trägheitsmoment

$$J = 98 \cdot p \cdot l \cdot D^4$$

Cilindro pieno / *Solid cylinder* / Vollzylinder

$$J = 98 \cdot p \cdot l \cdot (D^4 - d^4)$$

Cilindro cavo / *Hollow cylinder* / Hohlzylinder

Conversione di una massa in movimento lineare in un momento d'inerzia riferito all'albero del motore

Conversion of a mass having a linear movement into a moment of inertia related to the motor shaft.

Umwandlung einer Masse mit Linearbewegung in ein Trägheitsmoment, das auf die Motorwelle bezogen ist.

$$J = 91.2 \cdot m \cdot \frac{v^2}{n^2}$$

Conversione di diversi momenti d'inerzia di massa a velocità diverse in un momento d'inerzia riferito all'albero motore.

Conversion of various mass moments of inertia having different speeds into a moment of inertia related to the motor shaft.

Umwandlung von verschiedenen Trägheitsmomenten mit unterschiedlichen Geschwindigkeiten in ein Trägheitsmoment, das auf die Motorwelle bezogen ist.

$$J_a = \frac{J_2 \cdot n_2^2 + J_3 \cdot n_3^2 \dots}{n_1^2}$$

P	= Potenza motore
m	= Massa
v	= Velocità lineare
F	= Forza
n	= Velocità di rotaz.
g	= 9,81
M	= Coppia del motore
r	= Raggio
J	= Inerzia
l	= Lunghezza
d	= Diametro interno
D	= Diametro esterno
p	= Peso specifico

<i>Rated power</i>
<i>Mass</i>
<i>Linear speed</i>
<i>Force</i>
<i>Rotation speed</i>
<i>9.81</i>
<i>Motor torque</i>
<i>Radius</i>
<i>Moment of inertia</i>
<i>Length</i>
<i>Inner diameter</i>
<i>Outer diameter</i>
<i>Specific weight</i>

Motorleistung	[kW]
Masse	[kg]
Lineargeschwindigkeit	[m/min]
Kraft	[N]
Drehzahl	[min ⁻¹]
9.81	[m/sec]
Motor-Drehmoment	[Nm]
Radius	[mm]
Trägheitsmoment	[kgm ²]
Länge	[mm]
Innendurchmesser	[mm]
Außendurchmesser	[mm]
Spezifisches Gewicht	[kg/dm ³]

Catalogo modello CT01IGBD4

12/00

Questo catalogo annulla e sostituisce ogni precedente edizione o revisione. Ci riserviamo il diritto di apportare modifiche senza preavviso.

This catalogue cancels and replace any previous edition and revision. We reserve the right to implement modifications without notice.

Dieser Katalog setzt alle früheren Ausgaben ausser Kraft. Wir behalten uns das Recht vor, Änderungen ohne Ankündigung vorzunehmen.

Qualora questo catalogo non Vi sia giunto in distribuzione controllata, l'aggiornamento dei dati ivi contenuto non è assicurato. In tal caso al fine di verificare se questa è l'ultima versione emessa, contattare l'ufficio commerciale STM.

If you did not receive this catalogue in controlled distribution, STM does not guarantee the updating of the listed data. In this case it is necessary to contact STM sales-department.

STM hat sich die Möglichkeit, automatisch die aktuelle Verteilung aller Kataloge zu überprüfen. Benötigen sie die Nummer der aktuellen Auflage, so wenden Sie sich bitte an den Vertrieb von STM.